

City of Beaumont

Plot Plan for Patio Covers

Date _____

Name _____ Phone # _____

Address _____ Zip _____

BACK PROPERTY LINE

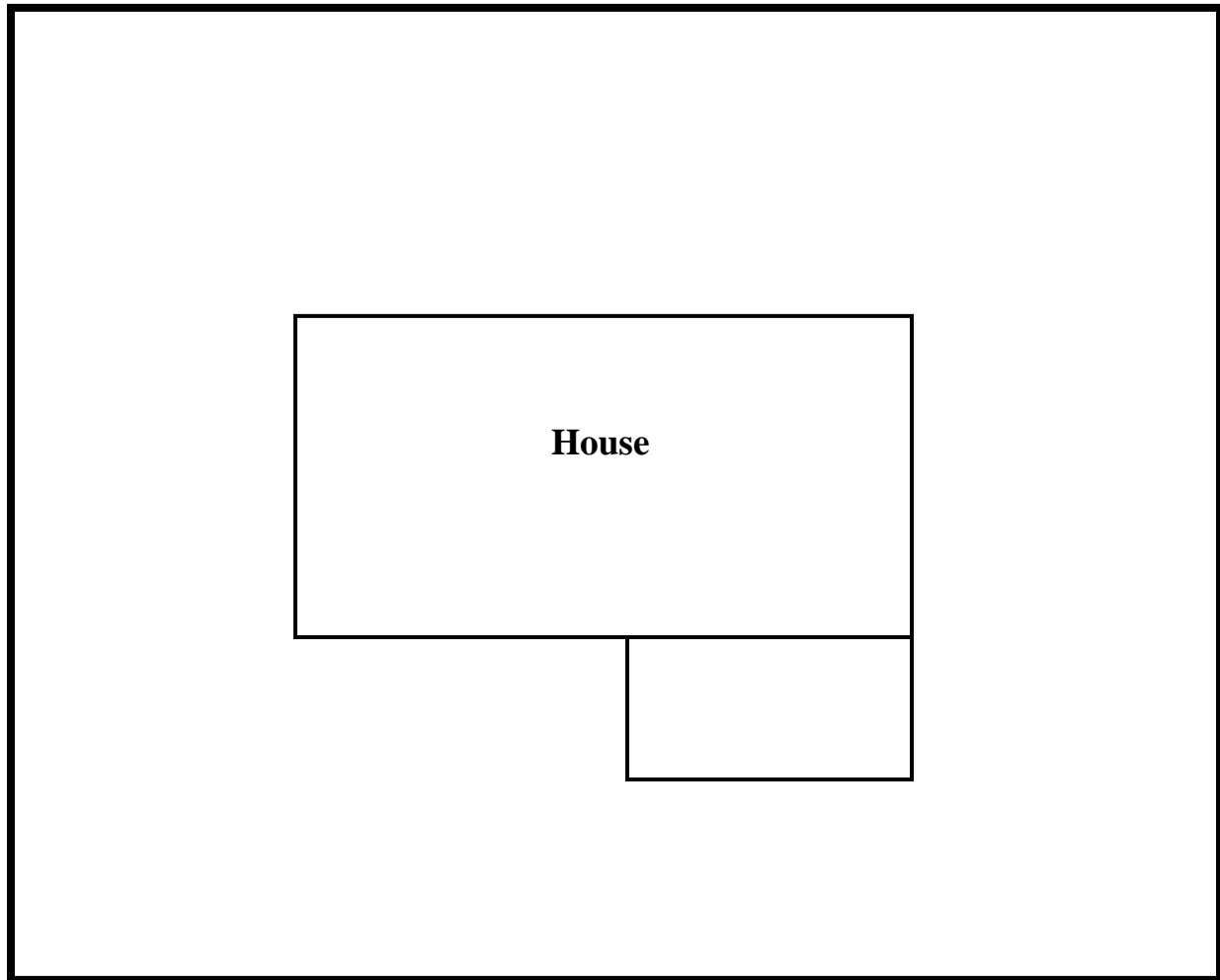

FRONT PROPERTY LINE

- Show patio roof dimensions and where it is on the property, where the posts will be and how far the patio cover is from the property lines.
- For all other structures, i.e., retaining walls, garden walls, etc. show their location on the property indicating dimensions.
- Indicate location of all slopes; up slope or down slope

Patio Dimensions Worksheet

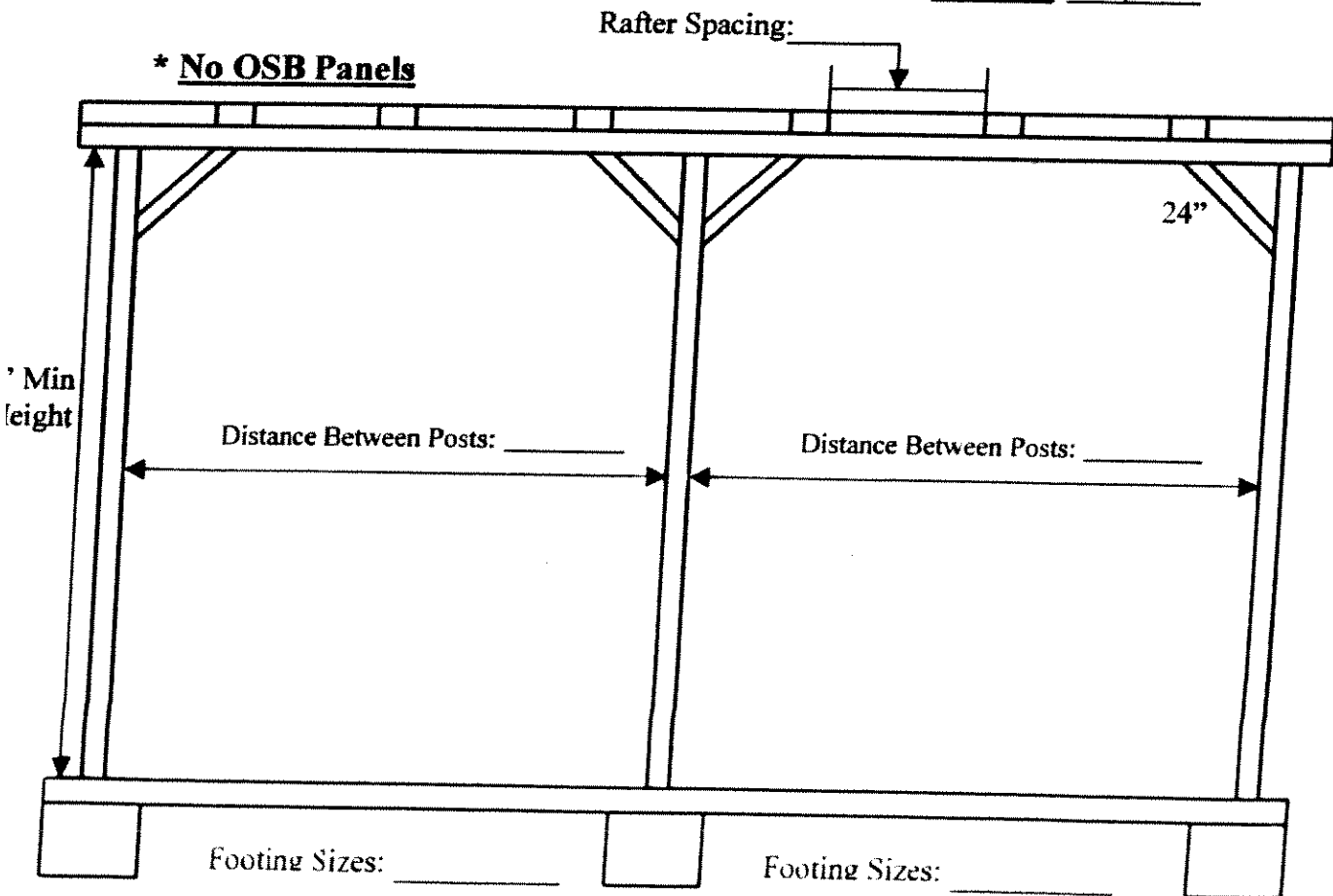
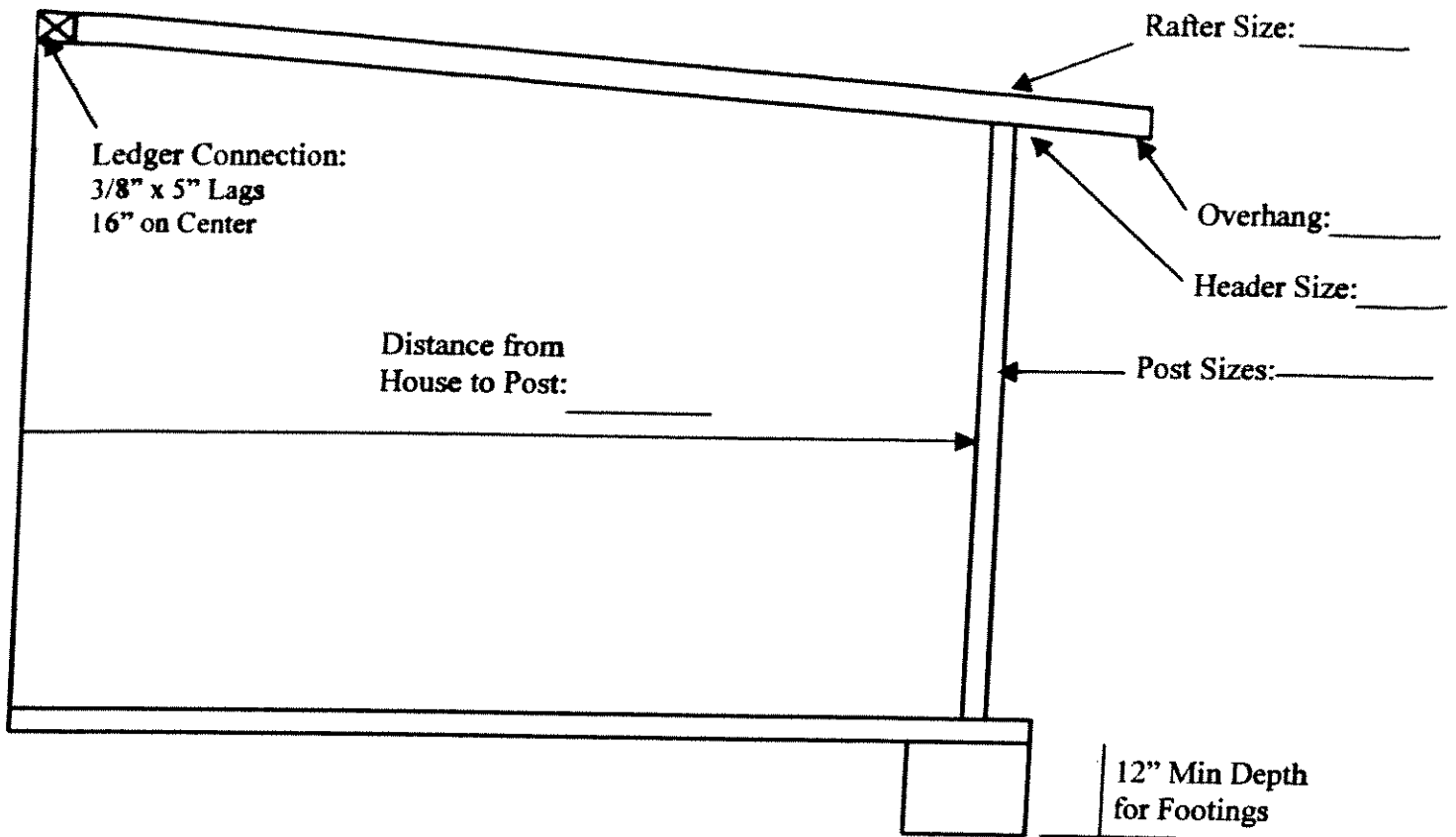

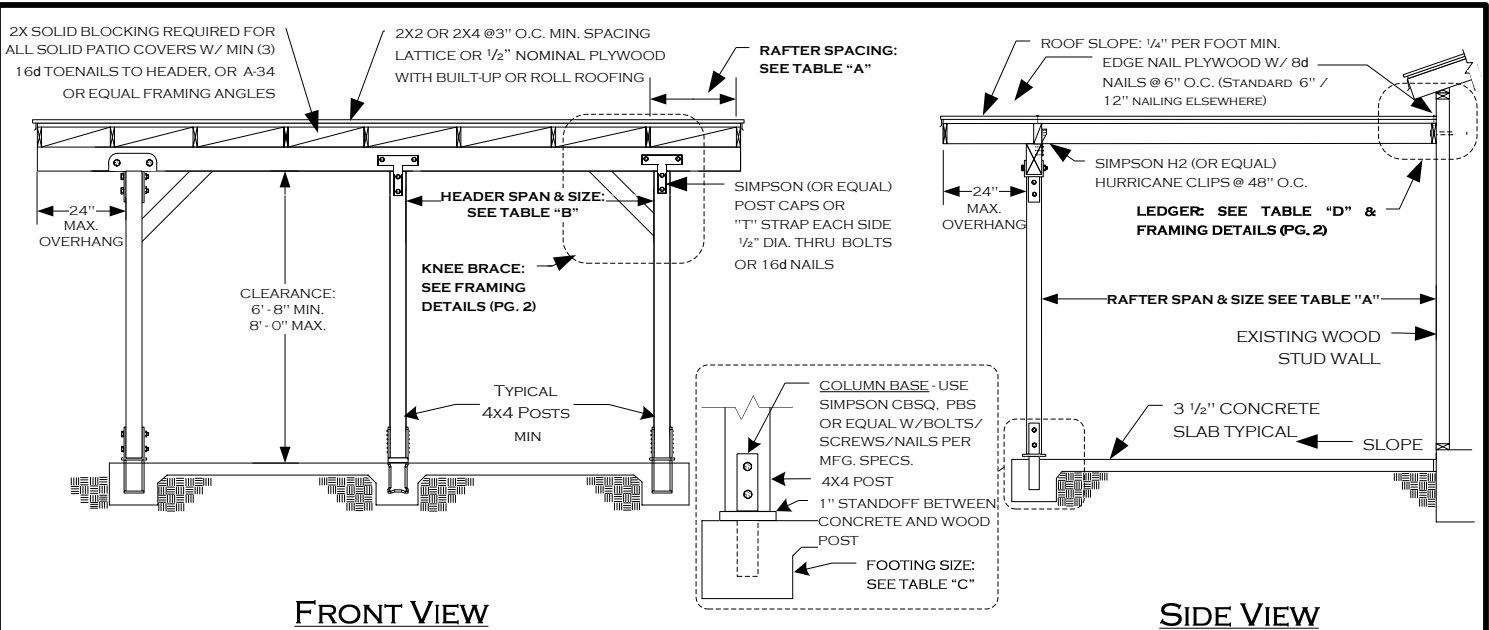

TABLE "A" RAFTER SPANS (DOUGLAS FIR #2 OR BETTER)		
SIZE	SPACING	SPAN
2 x 4	12" O.C.	9' - 10"
	16" O.C.	8' - 11"
	24" O.C.	7' - 8"
	32" O.C.	*6' - 3"
2 x 6	12" O.C.	15' - 4"
	16" O.C.	13' - 9"
	24" O.C.	11' - 3"
	32" O.C.	*9' - 7"
2 x 8	12" O.C.	20' - 0"
	16" O.C.	18' - 2"
	24" O.C.	14' - 10"
	32" O.C.	*12' - 8"
2 x 10	12" O.C.	20' - 0"
	16" O.C.	20' - 0"
	24" O.C.	18' - 11"
	32" O.C.	*16' - 2"
4 x 4	24" O.C.	10' - 0"
	32" O.C.	*9' - 3"
	48" O.C.	*7' - 8"
4 x 6	24" O.C.	15' - 11"
	32" O.C.	*13' - 9"
	48" O.C.	*11' - 3"
4 x 8	24" O.C.	20' - 0"
	32" O.C.	*18' - 2"
	48" O.C.	*14' - 10"

TABLE "B" HEADER SIZE & SPANS (DOUGLAS FIR #2 OR BETTER)		
RAFTER SPAN	HEADER	
	SPAN	SIZE
UP TO 12'-0"	8'-0" MAX	4 x 6
	10'-0" MAX	4 x 8
	12'-0" MAX	4 x 10
	14'-0" MAX	4 x 12
12'-1" TO 20'-0"	8'-0" MAX	4 x 8
	10'-0" MAX	4 x 10
	12'-0" MAX	4 x 12
	14'-0" MAX	4 x 14

TABLE "C" FOOTING SIZE
BASED ON 1000 P.S.F. SOIL BEARING PRESSURE.
18" SQ. X 12" DEEP
18" SQ. X 12" DEEP
18" SQ. X 12" DEEP
18" SQ. X 12" DEEP
24" SQ. X 12" DEEP
24" SQ. X 12" DEEP
24" SQ. X 12" DEEP
24" SQ. X 12" DEEP

TABLE "D" LEDGER BOLTING Δ
ALL LAG BOLTS SHALL HAVE 1/4" PRE-DRILLED HOLES - (SEE NOTE 2)
1/2" DIA. X 5" LONG AT 16" O.C. STAGGERED
(2) 3/8" DIA X 5" LONG AT 16" O.C.

NOTES:

- TWO 2X MEMBERS MAY BE SUBSTITUTED FOR ONE 4X HORIZONTAL FRAMING MEMBER.
- LAG BOLTS MUST FULLY ENGAGE A WOOD STUD OR RIM JOIST AND BE PROVIDED WITH APPROPRIATE WASHERS. LAG BOLTS SHALL BE LOCATED A MINIMUM OF 1-1/2" FROM THE TOP OR BOTTOM OF THE LEDGER.
- NOT DESIGNED TO BE ENCLOSED - ADDITIONAL ENGINEERING ANALYSIS WILL BE REQUIRED IF ENCLOSED.
- SEE PAGE 2 OF 2 FOR CONSTRUCTION DETAILS.
- ARTIFICIAL LIGHTING IS REQUIRED IN ROOMS THAT HAVE WINDOW OPENINGS INTO THE COVERED PATIO AREA IF THE TOTAL WINDOW AREA IN THAT ROOM IS LESS THAN 10% OR THE FLOOR AREA OF THE ROOM OR 20 SQUARE FEET, WHICHEVER IS GREATER. Δ

DISCLAIMER:

ALTERNATE PATIO DESIGNS MAY BE POSSIBLE WHEN PROVIDED WITH AN ENGINEERED ANALYSIS. USE OF THIS CONVENTIONAL STANDARD DESIGN IS AT THE USER'S RISK AND CARRIES NO IMPLIED OR INFERRED GUARANTEE AGAINST FAILURE OR DEFECTS.

* THIS SPACING AND SPAN IS FOR LATTICE PATIO COVERINGS ONLY.

WESTERN RIVERSIDE COUNTY CODE UNIFORMITY PROGRAM			
	CITY OF BEAUMONT		
	BUILDING DEPARTMENT		
PATIO COVER STANDARD			
(951)769-8529		550 E. 6TH ST BEAUMONT CA 92223	
(951)769-9678		1/1/2008 Δ	PATIOStd2008(7).vSD
		PAGE 1 OF 2	

KNEE BRACE DETAIL AT END POSTS

(REQUIRED WHEN RAFTER SPAN EXCEEDS 12 FT.)

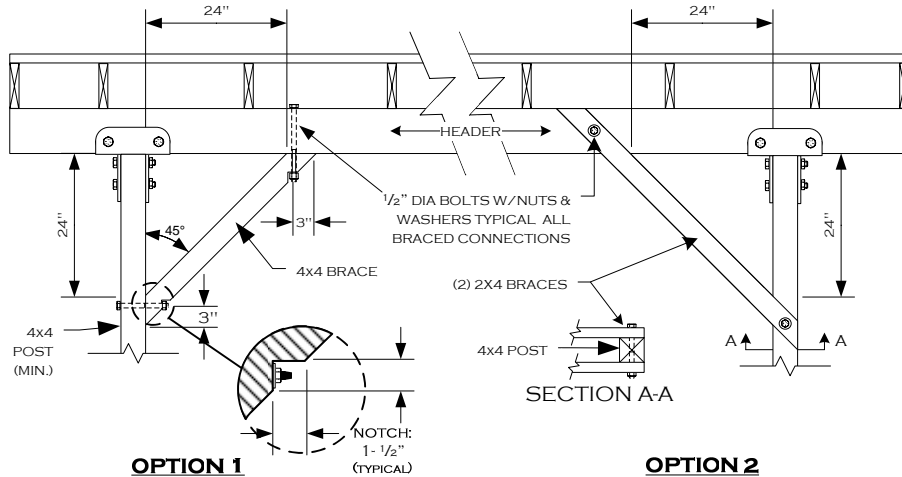

LEDGER ATTACHMENT

DETAIL

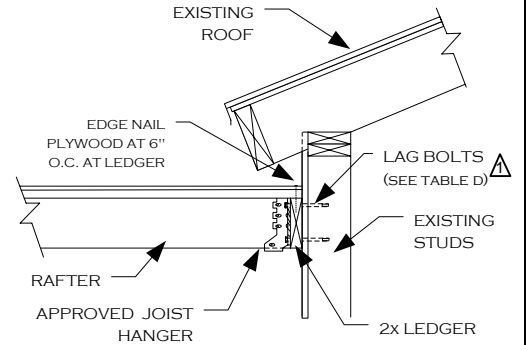

NOTES:

1. USE A CONTINUOUS 2X LEDGER – SAME DEPTH AS RAFTER OR LARGER
2. SEE TABLE "D" FOR BOLTING REQUIREMENTS

INVERTED HEADER DESIGN OPTION (LATTICE ONLY)

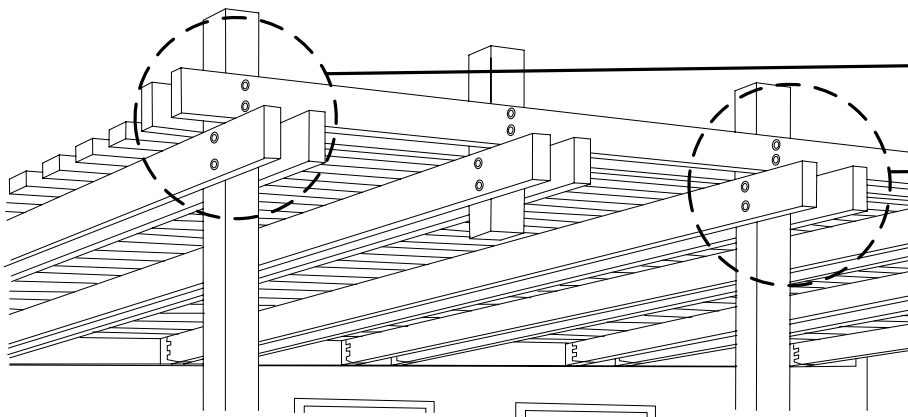

NOTE: KNEE BRACING REQUIRED WHEN RAFTER SPAN EXCEEDS 12 FEET

2X FASCIA (OVERHANG) ATTACHMENT – LATTICE ONLY

OPTION 1

OPTION 2

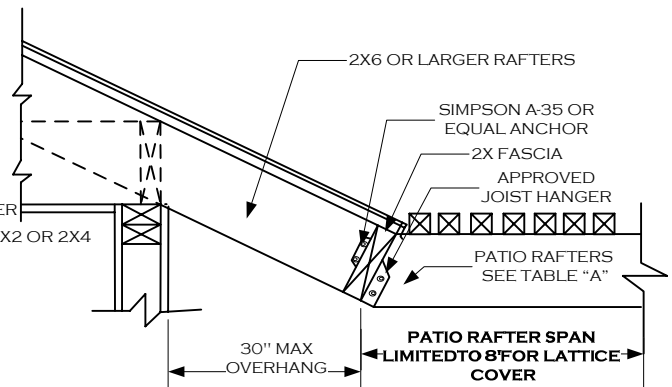
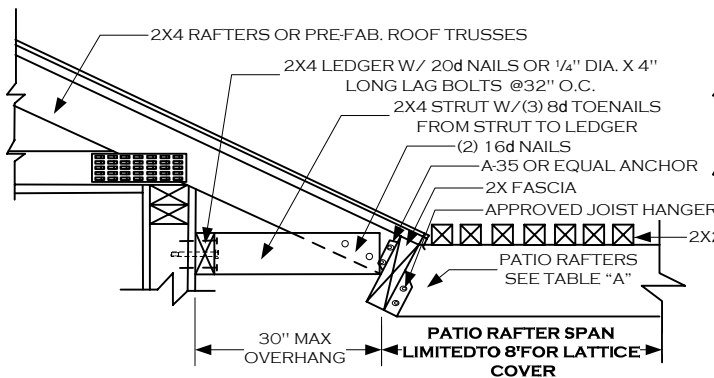

NOTE: VERIFY STRUCTURAL SOUNDNESS OF ROOF RAFTERS FOR DECAY OR TERMITE DAMAGE, AND REPLACE WITH LIKE MATERIALS AS NEEDED, AFTER CONSULTATION WITH THE BUILDING DEPARTMENT.

WESTERN RIVERSIDE COUNTY CODE UNIFORMITY PROGRAM



CITY OF BEAUMONT BUILDING DEPARTMENT

PATIO COVER STANDARD

(951)769-8529

550 E. 6TH ST BEAUMONT CA 92223

(951)769-9678

1/1/2008

PATIOStd2008(7).VSD

PAGE 2 OF 2

CBSQ Column Bases

SIMPSON

Strong-Tie



This product is preferable to similar connectors because of
a) easier installation, b) higher loads, c) lower installed cost,
or a combination of these features.

The CBSQ uses Simpson's SDS screws, which allow for fast installation, reduced reveal and high capacity, provides a greater net section area of the column compared to bolts.

MATERIAL: See table.

FINISH: Galvanized, available in HDG with HDG screws.

INSTALLATION: • Use all specified fasteners. See General Notes.

- Install Simpson's SDS 1/4"x2" wood screws, which are provided with the column base. (Lag screws will not achieve the same load.)
- Post bases do not provide adequate resistance to prevent members from rotating about the base and therefore are not recommended for non top-supported installations (such as fences or unbraced carports).

CODES: See page 12 for Code Listing Key Chart.

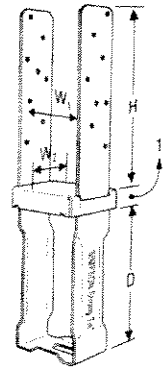

CBSQ-SDS2
U.S. Patent 4,924,648

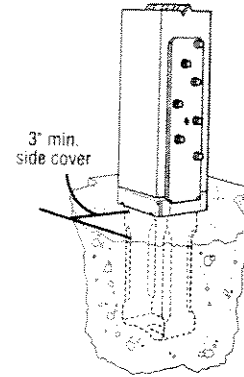

Typical CBSQ-SDS2
Installation

These products are available with additional corrosion protection. Additional products on this page may also be available with this option, check with Simpson for details.

Model No.	Nominal Column Size	Material		Dimensions				Number of Simpson SDS 1/4"x2" Screws	Allowable Loads			Code Ref.
		Base (Ga)	Strap (Ga x Width)	W ₁	W ₂	D	H		Uplift (133)	Uplift (160)	Down (100)	
CBSQ44-SDS2	4x4	12	10 ga x 2 1/4	3 9/16	3 1/2	7 1/16	8 9/16	14	5335	5335	10975	46, 107, 1-3
CBSQ46-SDS2	4x6	12	10 ga x 3	3 9/16	5 9/16	7 3/4	8 11/16	14	5335	5335	14420	
CBSQ66-SDS2	6x6	12	10 ga x 3	5 1/2	5 1/2	6 3/4	8 3/4	14	5710	6855	14420	

1. For higher downloads, solidly pack grout under 1" standoff plate before installing CBSQ into concrete. Base download on column or concrete, according to the code.
2. When using structural composite lumber columns, screws must be applied to the wide face of the column.
3. Downloads shall be reduced where limited by buckling capacity of the column.
4. Designer is responsible for concrete design.

CBQ and CBSQ

To order with screws, specify
CBQ-SDS2 or CBSQ-SDS2.

To order without screws, specify
CBQ or CBSQ.

caps & bases